

AC Output Modules

D2-08TA AC Output <--->	
Outputs per Module	8
Commons per Module	1 (2 I/O terminal points)
Output Type	SSR (Triac)
Operating Voltage	15-264 VAC
Peak Voltage	264 VAC
ON Voltage Drop	< 1.5 VAC (>0.1A) < 3.0 VAC (<0.1A)
AC Frequency	47 to 63 Hz
Minimum Load Current	10 mA
Max Load Current	0.5A/point; 4A/common
Max Leakage Current	4mA (264 VAC, 60 Hz) 1.2 mA (100 VAC, 60 Hz) 0.9 mA (100 VAC, 50 Hz)
Max Inrush Current	10A for 10 ms
Base Power Required 5VDC	250 mA
OFF to ON Response	1ms
ON to OFF Response	1ms + 1/2 cycle
Terminal Type (included)	Removable; D2-8IOCON
Status Indicator	Logic side
Weight	2.8 oz. (80g)
Fuses	1 per common, 6.3A slow blow, non-replaceable

See page 4-78 for part numbers of ZIPLink cables and connection modules compatible with this I/O module.

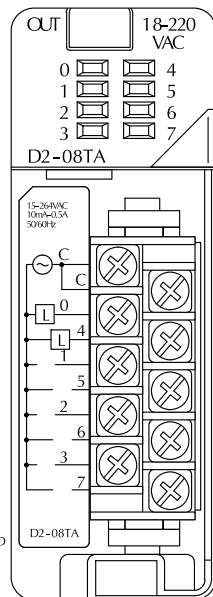
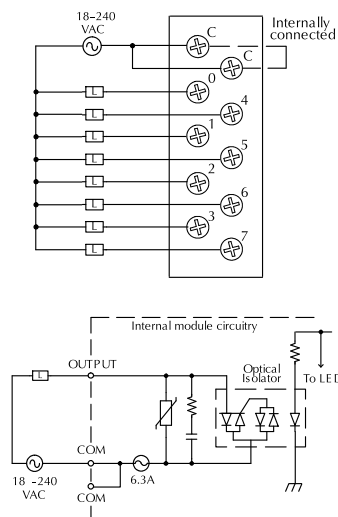
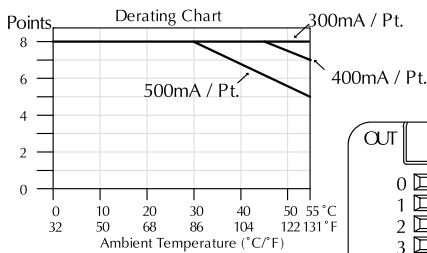

F2-08TA AC Output <--->	
Outputs per Module	8
Commons per Module	2 (Isolated)
Output Type	SSR (Triac with zero crossover)
Operating Voltage	24-140 VAC
Peak Voltage	140 VAC
ON Voltage Drop	1.6 V(rms) @ 1.5A
AC Frequency	47 to 63 Hz
Minimum Load Current	50 mA
Max Load Current	1.5A / pt @ 30°C 1.0A / pt @ 60°C 4.0A / common; 8.0A / module @ 60°C
Max Leakage Current	0.7 mA(rms)
Peak One Cycle Surge Current	15A
Base Power Required 5VDC	250 mA
OFF to ON Response	0.5 ms - 1/2 cycle
ON to OFF Response	0.5 ms - 1/2 cycle
Terminal Type (included)	Removable; D2-8IOCON
Status Indicator	Logic side
Weight	3.5 oz. (99g)
Fuses	None

See page 4-78 for part numbers of ZIPLink cables and connection modules compatible with this I/O module.

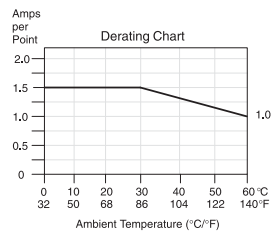

Derating Note: All outputs can be run at the current per point shown.

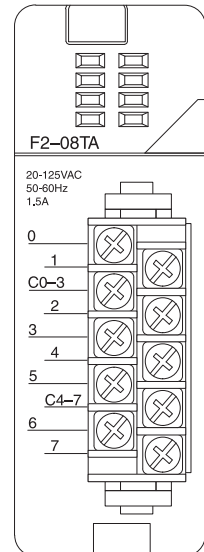
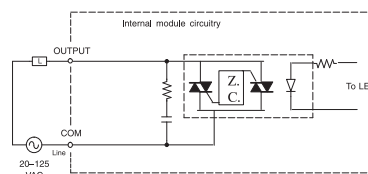
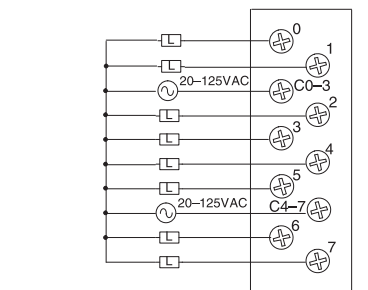

Cut PLC wiring time to minutes instead of hours

The ZIPLink wiring system eliminates the normally tedious process of wiring PLC I/O to terminal blocks. Simply plug one end of a ZIPLink pre-wired terminal block cable into your I/O module and the other end into a ZIPLink connector module. It's that easy. ZIPLinks use half the space, at a fraction of the total cost of terminal blocks.

ZIPLinks are available in a variety of styles to suit your needs, including fused, relay and sensor/LED connector modules. ZIPLinks are available for all DL205 Series PLC discrete and analog input and output modules.

For complete information see ZIPLinks in the Terminal Blocks and Wiring Solutions section.



Specify your ZIPLink system

Use the Compatibility Matrix table below:

Step 1	Locate the I/O module part number.
Step 2	Locate Connector Module Type. (Feedthrough Module, Fuse Module, etc...)
Step 3	Select the cable length by replacing the # symbol with: Blank = 0.5m, -1 = 1.0m, -2 = 2.0m ¹
¹ Note: Cable part number denotes compatibility between Connector Module and I/O Modules.	

ZIPLink Wiring System Compatibility Matrix for DL205 PLCs										
Step 2: Connector Module Type		Feedthrough Modules		Fuse Modules		Relay Modules	Sensor Input Modules		Pigtail Cable	
Step 1: I/O Module	Number of Terminals	ZL-RTB20	ZL-RTB40	ZL-RFU20	ZL-RFU40	ZL-RRL16-24	ZL-LTB16-24	ZL-LTB32-24		
Step 3: Cables										
Inputs										
I/O Module	D2-08ND3	10	ZL-D2-CBL10#							
	D2-16ND3-2	19	ZL-D2-CBL19#				ZL-D2-CBL19#		ZL-D2-CBL19#P	
	D2-32ND3	40		ZL-D24-CBL40#				ZL-D24-CBL40#	ZL-D24-CBL40#P	
	D2-32ND3-2	40		ZL-D24-CBL40#				ZL-D24-CBL40#	ZL-D24-CBL40#P	
	D2-08NA-1	10	ZL-D2-CBL10#							
	D2-08NA-2	10	ZL-D2-CBL10#							
	D2-16NA	19	ZL-D2-CBL19#						ZL-D2-CBL19#P	
	Outputs									
	D2-04TD1*	10	ZL-D2-CBL10#							
	D2-08TD1	10	ZL-D2-CBL10#							
	D2-08TD2	10	ZL-D2-CBL10#							
	D2-16TD1-2	19	ZL-D2-CBL19#		ZL-D2-CBL19#		ZL-D2-CBL19#			ZL-D2-CBL19#P
	D2-16TD2-2	19	ZL-D2-CBL19#		ZL-D2-CBL19#					ZL-D2-CBL19#P
	D2-32TD1	40		ZL-D24-CBL40#		ZL-D24-CBL40#				ZL-D24-CBL40#P
	D2-32TD2	40		ZL-D24-CBL40#		ZL-D24-CBL40#				ZL-D24-CBL40#P
	D2-08TA	10	ZL-D2-CBL10#							
	F2-08TA	10	ZL-D2-CBL10#							
	D2-12TA	19	ZL-D2-CBL19#		ZL-D2-CBL19#					ZL-D2-CBL19#P
	D2-04TRS*	10	ZL-D2-CBL10#							
D2-08TR	10	ZL-D2-CBL10#								
F2-08TRS*	19	ZL-D2-CBL19#							ZL-D2-CBL19#P	
F2-08TR**	10	ZL-D2-CBL10#								
D2-12TR	19	ZL-D2-CBL19#		ZL-D2-CBL19#					ZL-D2-CBL19#P	
Combo In/Out										
D2-08CDR	10	ZL-D2-CBL10#								

*Caution: The D2-04TD1, D2-04TRS, and F2-08TRS outputs are derated not to exceed 2 Amps per point and 2 Amps per common when used with the ZIPLink wiring system.

**The F2-08TR outputs are derated not to exceed 2 Amps per point and 4 Amps per common when used with the ZIPLink wiring system.

ZIPLink Connector Module and Cable specifications found in Terminal Blocks and Wiring Section

Power Requirements

These charts help determine your power requirements

This section shows the amount of power supplied by each of the base power supplies and the amount of power consumed by each DL205 device. The Power Consumed charts list how much INTERNAL power from each power source is required for the DL205 devices. Use this information when calculating the power budget for your system.

In addition to the internal power sources, the DL205 bases offer a 24 VDC auxiliary power supply with external power connections. This auxiliary power supply can power external devices.

Use ZIPLinks to reduce power requirements

If your application requires a lot of relay outputs, consider using the ZIPLink AC or DC relay output modules. These modules can switch high current (10A) loads without putting a load on your base power budget. Refer to the Terminal Blocks and Wiring Solutions section in this catalog for more information.

This logo is placed next to the I/O modules that are supported by the ZIPLink connection systems. See the I/O module specifications at the end of this section.



Power Consumed		
Device	5V(mA)	24V Auxiliary
Operator Interface		
DV-1000	150	0
C-more Micro-Graphic	210	0

Power Supplied							
Device	Price	5V(mA)	24V Auxiliary	Device	Price	5V(mA)	24V Auxiliary
Bases				Bases			
D2-03B-1	<--->	2600	300	D2-06BDC1-1	<--->	2600	None
D2-03BDC1-1	<--->	2600	None	D2-06BDC2-1	<--->	2600	300
D2-04B-1	<--->	2600	300	D2-09B-1	<--->	2600	300
D2-04BDC1-1	<--->	2600	None	D2-09BDC1-1	<--->	2600	None
D2-06B-1	<--->	2600	300	D2-09BDC2-1	<--->	2600	300

Power Consumed		
Device	5V(mA)	24V Auxiliary
CPUs		
D2-230	120	0
D2-240	120	0
D2-250-1	330	0
D2-260	330	0
H2-WPLC*~**	680	0
DC Input Modules		
D2-08ND3	50	0
D2-16ND3-2	100	0
D2-32ND3	25	0
D2-32ND3-2	25	0
AC Input Modules		
D2-08NA-1	50	0
D2-08NA-2	100	0
D2-16NA	100	0
Input Simulator Module		
F2-08SIM	50	0
DC Output Modules		
D2-04TD1	60	20
D2-08TD1	100	0
D2-08TD2	100	0
D2-16TD1-2	200	80
D2-16TD2-2	200	0
F2-16TD1P	70	50
F2-16TD2P	70	50
D2-32TD1	350	0
D2-32TD2	350	0
AC Output Modules		
D2-08TA	250	0
F2-08TA	250	0
D2-12TA	350	0
Relay Output Modules		
D2-04TRS	250	0
D2-08TR	250	0
F2-08TR(S)	670	0
D2-12TR	450	0
Combination In/Out Module		
D2-08CDR	200	0

Power Consumed		
Device	5V(mA)	24V Auxiliary
Analog Modules		
F2-04AD-1	100	5
F2-04AD-2	110	5
F2-08AD-1	100	5
F2-08AD-2	100	5
F2-02DA-1	40	60 (note 1)
F2-02DA-1L	40	70 @ 12V (note 1)
F2-02DA-2	40	60
F2-02DA-2L	40	70 @ 12V
F2-02DAS-1	100	50 / channel
F2-02DAS-2	100	60 / channel
F2-08DA-1	30	50 (note 1)
F2-08DA-2	60	140
F2-4AD2DA	60	80 (note 1)
F2-8AD4DA-1	35	100 (note 1)
F2-8AD4DA-2	35	80 (note 1)
F2-04RTD	90	0
F2-04THM	110	60
Specialty Modules		
D2-CTRINT	50*	0
D2-CM / D2-EM	100/130	0
H2-CTRIO	400	0
D2-DCM	300	0
F2-DEVNETS	160	0
F2-SDS-1	160	0
H2-PBC	530	0
H2-EBC(-F)	450, (640)	0
H2-ECOM(-F)	450, (640)	0
H2-ECOM100	300	0
F2-CP128	235	0
Remote I/O		
H2-ERM(-F)	320, (450)	0
D2-RMSM	200	0
D2-RSSS	150	0
Programming Devices		
D2-HPP	200	0

*requires external 5VDC for outputs
Note 1: Add an additional 20 mA per output loop.